

RM50xQ Series

Reference Design

5G Module Series

Version: 1.3

Date: 2021-12-09

Status: Released



At Quectel, our aim is to provide timely and comprehensive services to our customers. If you require any assistance, please contact our headquarters:

Quectel Wireless Solutions Co., Ltd.

Building 5, Shanghai Business Park Phase III (Area B), No.1016 Tianlin Road, Minhang District, Shanghai 200233, China

Tel: +86 21 5108 6236

Email: info@quectel.com

Or our local offices. For more information, please visit:

<http://www.quectel.com/support/sales.htm>.

For technical support, or to report documentation errors, please visit:

<http://www.quectel.com/support/technical.htm>.

Or email us at: support@quectel.com.

Legal Notices

We offer information as a service to you. The provided information is based on your requirements and we make every effort to ensure its quality. You agree that you are responsible for using independent analysis and evaluation in designing intended products, and we provide reference designs for illustrative purposes only. Before using any hardware, software or service guided by this document, please read this notice carefully. Even though we employ commercially reasonable efforts to provide the best possible experience, you hereby acknowledge and agree that this document and related services hereunder are provided to you on an “as available” basis. We may revise or restate this document from time to time at our sole discretion without any prior notice to you.

Use and Disclosure Restrictions

License Agreements

Documents and information provided by us shall be kept confidential, unless specific permission is granted. They shall not be accessed or used for any purpose except as expressly provided herein.

Copyright

Our and third-party products hereunder may contain copyrighted material. Such copyrighted material shall not be copied, reproduced, distributed, merged, published, translated, or modified without prior written consent. We and the third party have exclusive rights over copyrighted material. No license shall be granted or conveyed under any patents, copyrights, trademarks, or service mark rights. To avoid ambiguities, purchasing in any form cannot be deemed as granting a license other than the normal non-exclusive, royalty-free license to use the material. We reserve the right to take legal action for noncompliance with abovementioned requirements, unauthorized use, or other illegal or malicious use of the material.

Trademarks

Except as otherwise set forth herein, nothing in this document shall be construed as conferring any rights to use any trademark, trade name or name, abbreviation, or counterfeit product thereof owned by Quectel or any third party in advertising, publicity, or other aspects.

Third-Party Rights

This document may refer to hardware, software and/or documentation owned by one or more third parties (“third-party materials”). Use of such third-party materials shall be governed by all restrictions and obligations applicable thereto.

We make no warranty or representation, either express or implied, regarding the third-party materials, including but not limited to any implied or statutory, warranties of merchantability or fitness for a particular purpose, quiet enjoyment, system integration, information accuracy, and non-infringement of any third-party intellectual property rights with regard to the licensed technology or use thereof. Nothing herein constitutes a representation or warranty by us to either develop, enhance, modify, distribute, market, sell, offer for sale, or otherwise maintain production of any our products or any other hardware, software, device, tool, information, or product. We moreover disclaim any and all warranties arising from the course of dealing or usage of trade.

Privacy Policy

To implement module functionality, certain device data are uploaded to Quectel’s or third-party’s servers, including carriers, chipset suppliers or customer-designated servers. Quectel, strictly abiding by the relevant laws and regulations, shall retain, use, disclose or otherwise process relevant data for the purpose of performing the service only or as permitted by applicable laws. Before data interaction with third parties, please be informed of their privacy and data security policy.

Disclaimer

- a) We acknowledge no liability for any injury or damage arising from the reliance upon the information.
- b) We shall bear no liability resulting from any inaccuracies or omissions, or from the use of the information contained herein.
- c) While we have made every effort to ensure that the functions and features under development are free from errors, it is possible that they could contain errors, inaccuracies, and omissions. Unless otherwise provided by valid agreement, we make no warranties of any kind, either implied or express, and exclude all liability for any loss or damage suffered in connection with the use of features and functions under development, to the maximum extent permitted by law, regardless of whether such loss or damage may have been foreseeable.
- d) We are not responsible for the accessibility, safety, accuracy, availability, legality, or completeness of information, advertising, commercial offers, products, services, and materials on third-party websites and third-party resources.

Copyright © Quectel Wireless Solutions Co., Ltd. 2021. All rights reserved.

About the Document

Revision History

Version	Date	Author	Description
1.0	2020-09-15	Kingson ZHANG	Initial
1.1	2020-09-23	Norton ZHANG	Updated several pin names.
1.2	2021-04-12	Norton ZHANG	<ol style="list-style-type: none"> 1. Updated document's application scope form RM500Q series to RM50xQ series. 2. Updated VCC reference circuit. 3. Updated the pin name of pin 67 from RESET_N to RESET#; pins 2, 4, 70, 72, and 74 from VCC_MODULE to VCC; pin 6 from FULL_CARD_PWR_OFF# to FULL_CARD_POWER_OFF#.
1.3	2021-12-09	Norton ZHANG	Corrected the network connection of PCIE_WAKE_N (Sheet 4).

Contents

About the Document.....	3
Contents.....	4
1 Reference Design.....	5
1.1. Introduction.....	5
1.2. Schematics.....	5

1 Reference Design

1.1. Introduction

This document provides the reference design for RM50xQ series module, including that for power supply, module interfaces, AP interfaces and (U)SIM interfaces.

The document is applicable to the following modules:

- RM500Q series
- RM502Q series
- RM505Q-AE

1.2. Schematics

The schematics illustrated in the following pages are provided for reference only.

Block Diagram

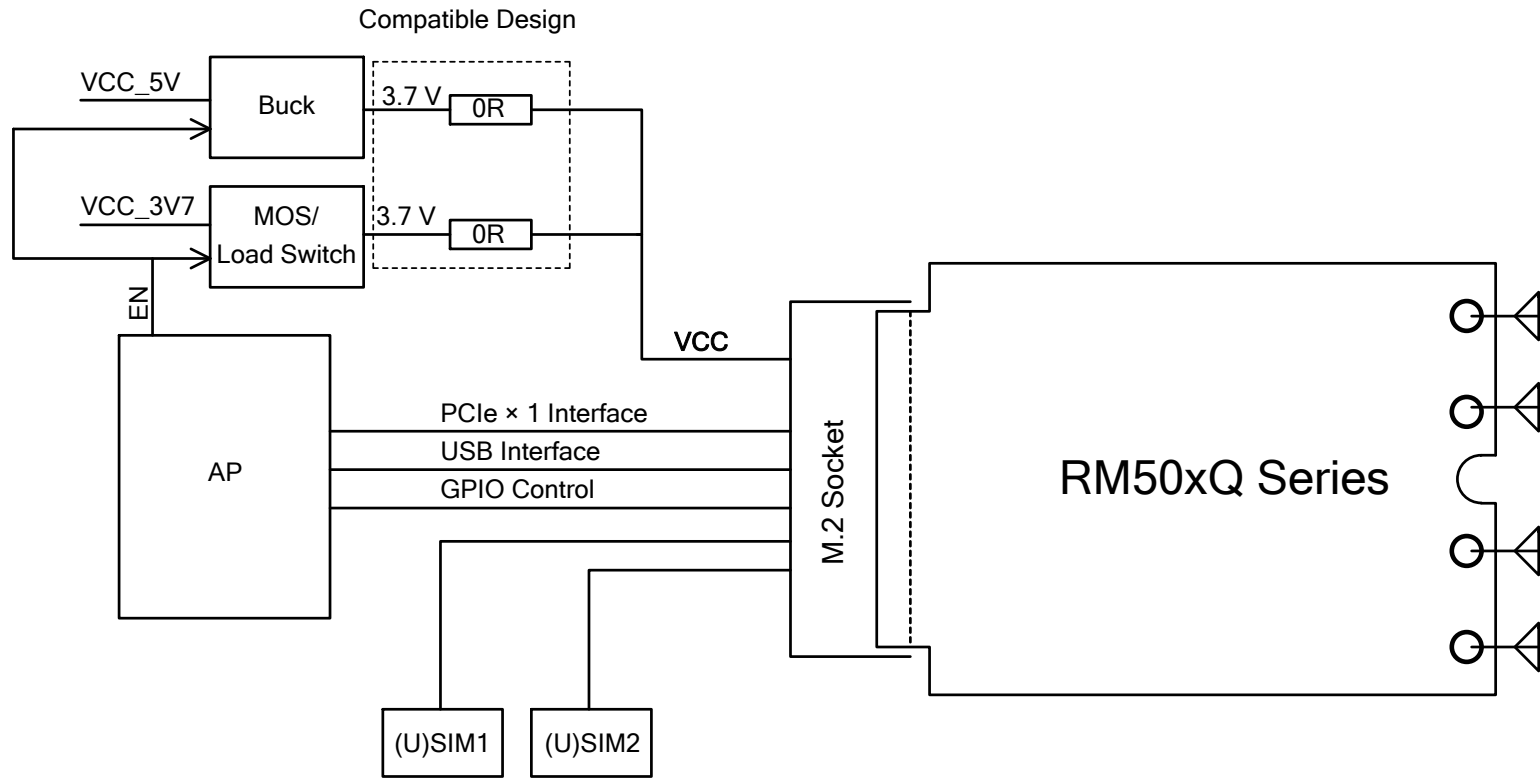

NOTE:

The location of antenna connectors is for reference only. For more details about antenna connectors, see *Quectel_RM50xQ_Series_Hardware_Design*.

Quectel Wireless Solutions

DRAWN BY Norton ZHANG	PROJECT RM50xQ Series	TITLE Reference Design
CHECKED BY Oscar LIU	SIZE A2	VER 1.3
SHEET	1 OF 5	DATE 2021/12/9

Power Supply Design

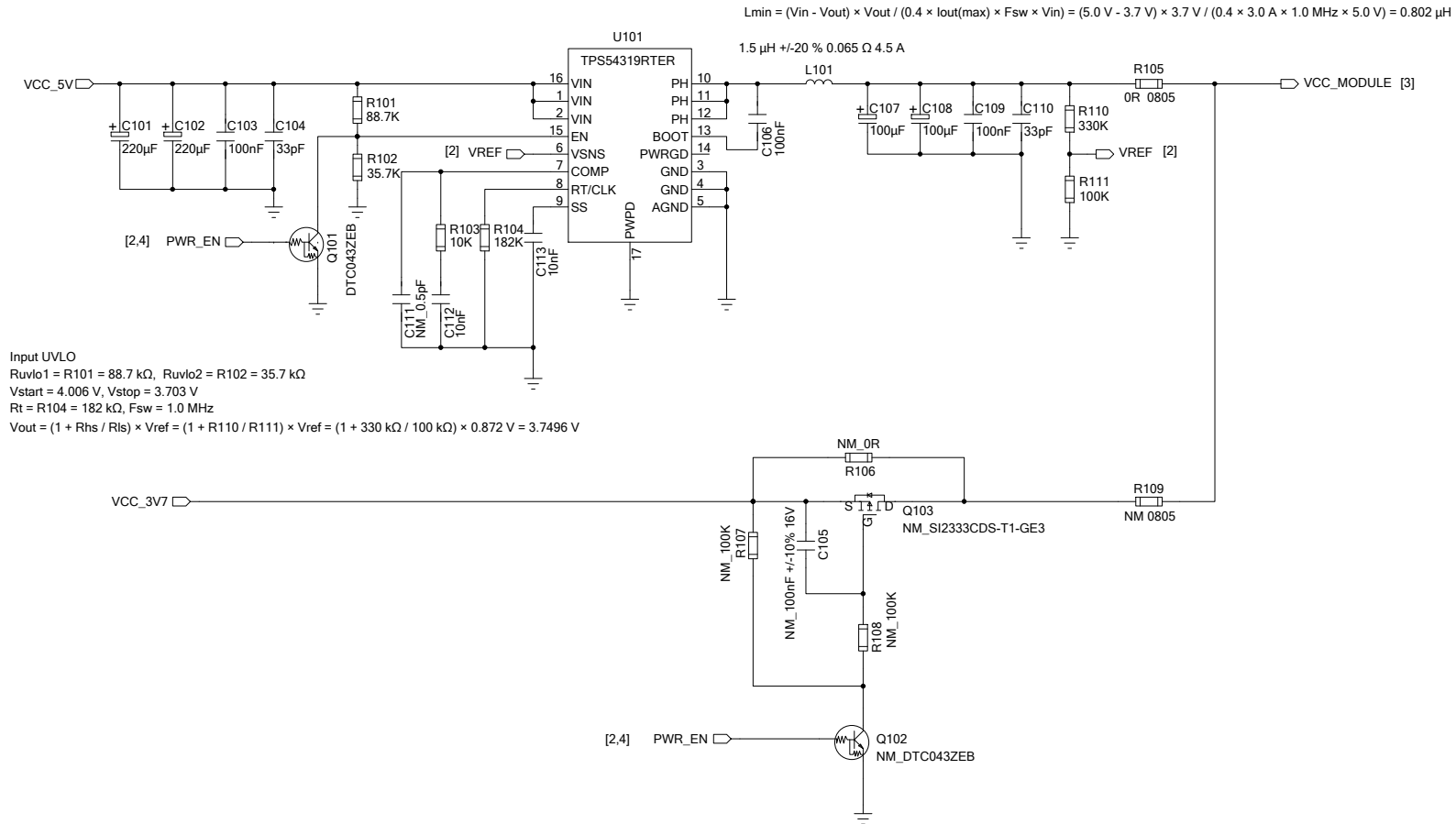

NOTE:

1. The power supply must be able to provide sufficient current up to 3 A or higher.
2. A compatible design is recommended for VCC power supply.

Quectel Wireless Solutions		
DRAWN BY Norton ZHANG	PROJECT RM50xQ Series	TITLE Reference Design
CHECKED BY Oscar LIU	SIZE A2	VER 1.3
SHEET	2 OF 5	DATE 2021/12/9

Module Interfaces

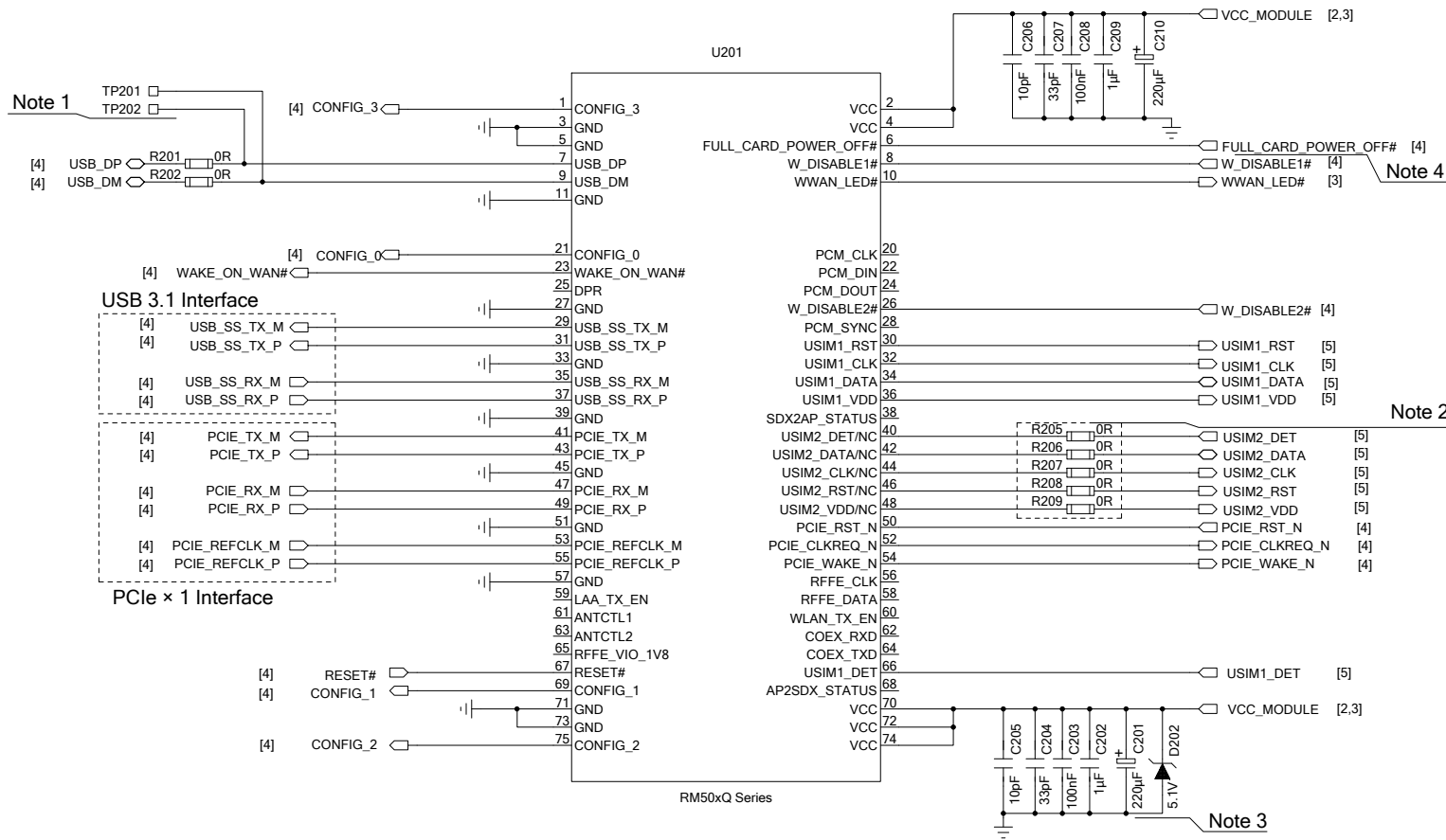

FULL_CARD_POWER_OFF#	Module
H	Turn On
L	Turn Off

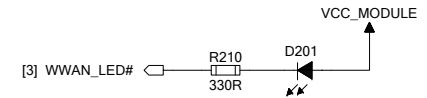

Note 2

RM50xQ Series	
Module	Pin 40, 42, 44, 46, 48
RM500Q-GL	(U)SIM2 Interface
RM502Q-GL	(U)SIM2 Interface
RM500Q-AE	NC
RM502Q-AE	NC
RM505Q-AE	(U)SIM2 Interface
RM500Q-CN	(U)SIM2 Interface

NOTE:

- It is recommended to reserve test points for the firmware upgrade over USB 2.0 interface and to minimize the stub length of USB test signals.
- R205 to R209 should be placed close to the M.2 socket. If the module has a built-in eSIM, R205 to R209 should not be mounted.
RM500Q-AE & RM502Q-AE do not support (U)SIM2 interface.
- It is recommended to use a zener diode D201 with a reverse zener voltage of 5.1 V and it should be placed close to the module pin.
- Use a AP GPIO to control FULL_CARD_POWER_OFF# of the module.

Quectel Wireless Solutions		
DRAWN BY Norton ZHANG	PROJECT RM50xQ Series	TITLE Reference Design
CHECKED BY Oscar LIU	SIZE A2	VER 1.3
SHEET	3 OF 5	DATE 2021/12/9

AP Interfaces

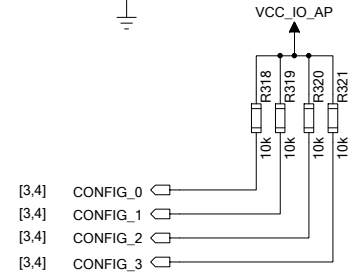
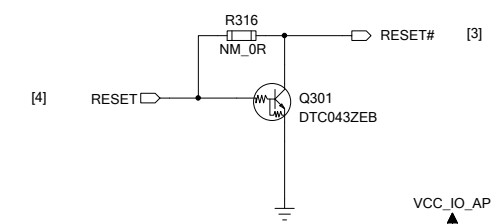
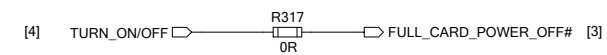
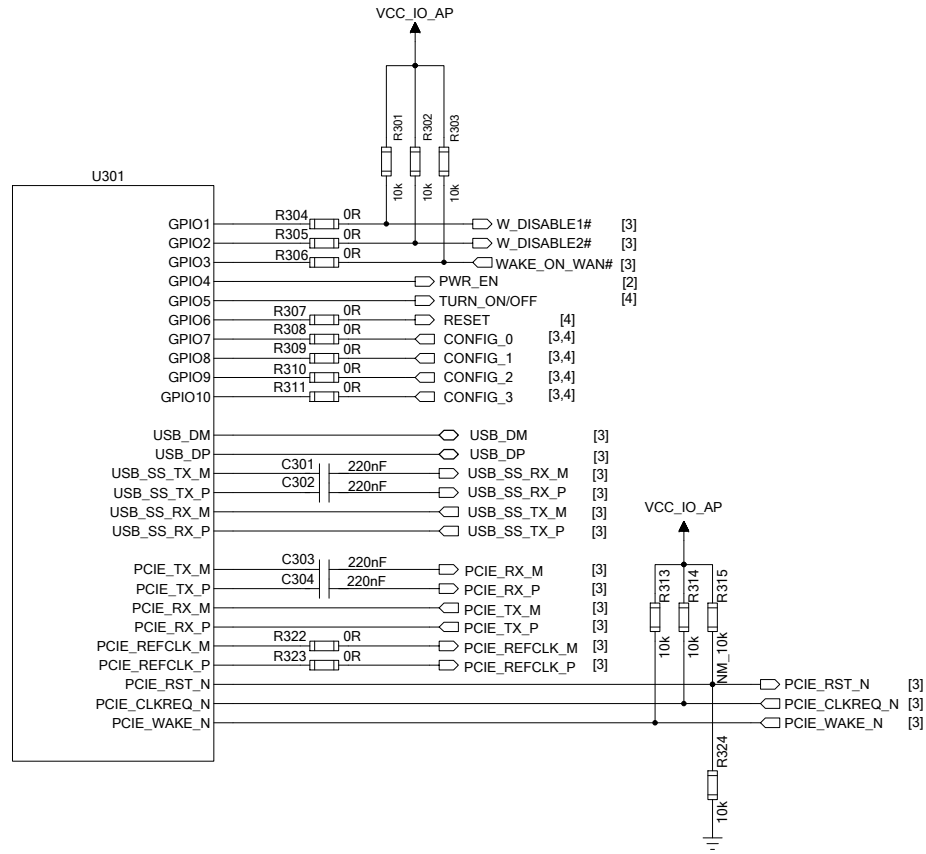

NOTE:

1. U301 represents your host.
2. Keep C301-C304 to the host as close as possible.
3. The differential impedance of USB 2.0/3.1 signal traces should be controlled to 90 Ω.
4. The differential impedance of PCIe signal traces should be controlled to 85 Ω.
5. If a USB connector is used, please keep ESD protection components to the USB connector as close as possible.

Quectel Wireless Solutions		
DRAWN BY Norton ZHANG	PROJECT RM50xQ Series	TITLE Reference Design
CHECKED BY Oscar LIU	SIZE A2	VER 1.3
SHEET	4 OF 5	DATE 2021/12/9

(U)SIM Interfaces Design

(U)SIM1

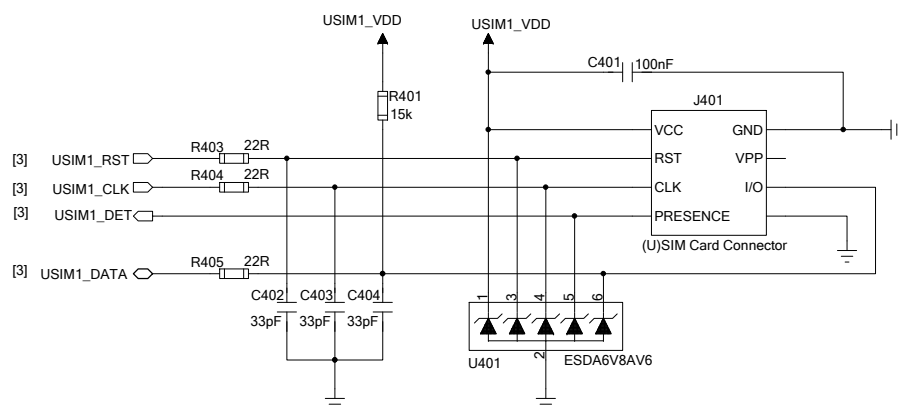

(U)SIM2

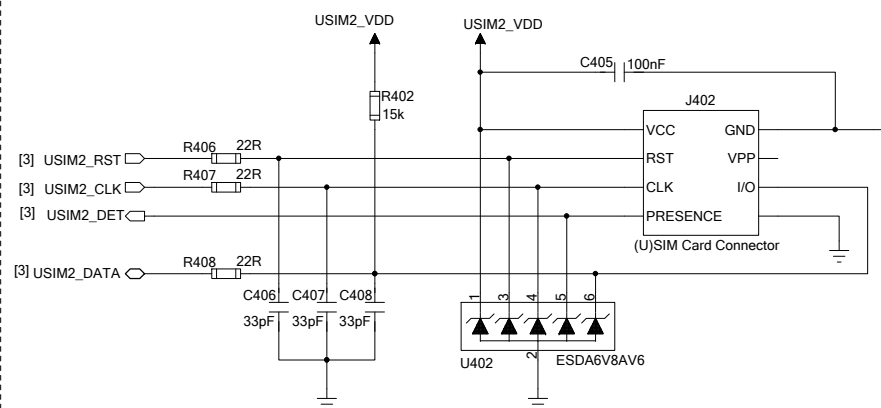

NOTE:

- The decoupling capacitors of (U)SIM signals and (U)SIM related resistors must be placed close to (U)SIM card connectors.
- RM50xQ series module provides the input pin(s) USIM_DET[1:2] to detect (U)SIM cards.
 - A normally short-circuited (U)SIM card connector is used in this reference design, and high-logic-level detection is supported. For more details, see the corresponding Hardware Design documents.
 - This pin is pulled LOW by default, and will be internally pulled up to 1.8 V by software configuration only when (U)SIM hot-plug is enabled by AT+QSIMDET.
- R403-R408 are used to suppress the EMI such as spurious transmission.
- A ESD diode array with a junction capacitance of lower than 10 pF should be placed as close to the (U)SIM card connector as possible for ESD protection.
- The (U)SIM card connector should be placed close to the M.2 socket, because a long PCB trace may lead to waveform distortion, which affects the signal quality.

Quectel Wireless Solutions

DRAWN BY Norton ZHANG	PROJECT RM50xQ Series	TITLE Reference Design
CHECKED BY Oscar LIU	SIZE A2	VER 1.3
SHEET	5 OF 5	DATE 2021/12/9