DATASHEET

AXS5106S

Self-capacitive touch controller

Version: V1.0
2022.11.02

Table of Contents

TABLE OF CONTENTS	2
REVISION HISTORY	3
GENERAL DESCRIPTION	4
1 FEATURES	4
1.1 KEY FEATURES.....	4
1.2 PIN LAYOUT	5
2 FUNCTION OVERVIEW	6
2.1 BLOCK DIAGRAM	6
2.1.1 AFE.....	6
2.1.2 Interface.....	6
2.1.3 Embedded MCU	7
2.2 WORK MODES.....	7
2.2.1 Normal mode	8
2.2.2 Idle mode	8
2.2.3 LPWG mode.....	8
2.2.4 Sleep mode.....	8
3 COMMUNICATION INTERFACE	9
4 ELECTRICAL SPECIFICATIONS	10
4.1 ABSOLUTE MAXIMUM RATINGS	10
4.2 RECOMMENDED OPERATING CONDITION	10
4.3 AC CHARACTERISTICS	10
5 PACKAGE	11
6 ORDERING INFORMATION	11
7 DISCLAIMER	12

REVISION HISTORY

Date	Revision #	Description	Page	Auditor
August 15, 2022	Preliminary	Original	12	TXH
November 2, 2022	V1.0	The VIH max description is changed to IOVCC	12	TXH

GENERAL DESCRIPTION

AXS5106S is a high-performance self-capacitor touch controller that supports various self-capacitor sensor patterns and has excellent signal-to-noise ratio to achieve high accuracy and linearity while maintaining ultra-low power consumption. It is very suitable for portable mobile devices such as smart watches and smart bracelets.

1 Features

1.1 Key features

- ◆ Highly sensitive self-capacitance detection technology
- ◆ Support up to 13 channels
- ◆ The maximum screen size is 3 inches
- ◆ Support GF, GG, OGS and other screen structure
- ◆ Support various ITO Sensor patterns (triangles, squares, etc.)
- ◆ Support four work modes: Normal mode, Idle mode, LPWG (low power wake-up gesture) mode, Sleep mode
- ◆ The sleep mode power consumption is as low as 5uA, the LPWG mode consumption is as low as 10uA, the Idle mode consumption is as low as 100uA, and the normal mode power consumption is as low as 1.2mA
- ◆ Touch point report rate up to 240Hz;
- ◆ Auto calibration
- ◆ Supports I2C interfaces
- ◆ Support online programming
- ◆ Single power supply 2.7V to 3.6V
- ◆ Package: QFN20 3x3x0.55mm
- ◆ The AXS5106S is dedicated for self-capacitive touch panel; its typical applications are listed as follows:
 - Smart watch, Smart bracelet
 - GPS navigator
 - Digital camera
 - Game consoles
 - Portable media player

1.2 Pin layout

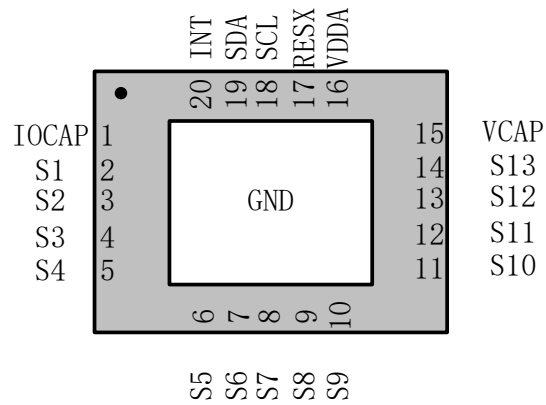

PIN Name	Description	Note
S1~S13	Sensor channels	
SCL/SDA	IIC	I2C clock input /I2C data input and output
RESX	Reset input	active low
INT	Interrupt output	External interrupt to the host
IOCAP	Connect 1uF capacitor	
VCAP	Connect 1uF capacitor	
VDDA	Power supply	2.7~3.6V, Connect 1-10uF capacitor

2 Function Overview

2.1 Block diagram

The overall system block diagram of the AXS5106S is shown as Figure below.

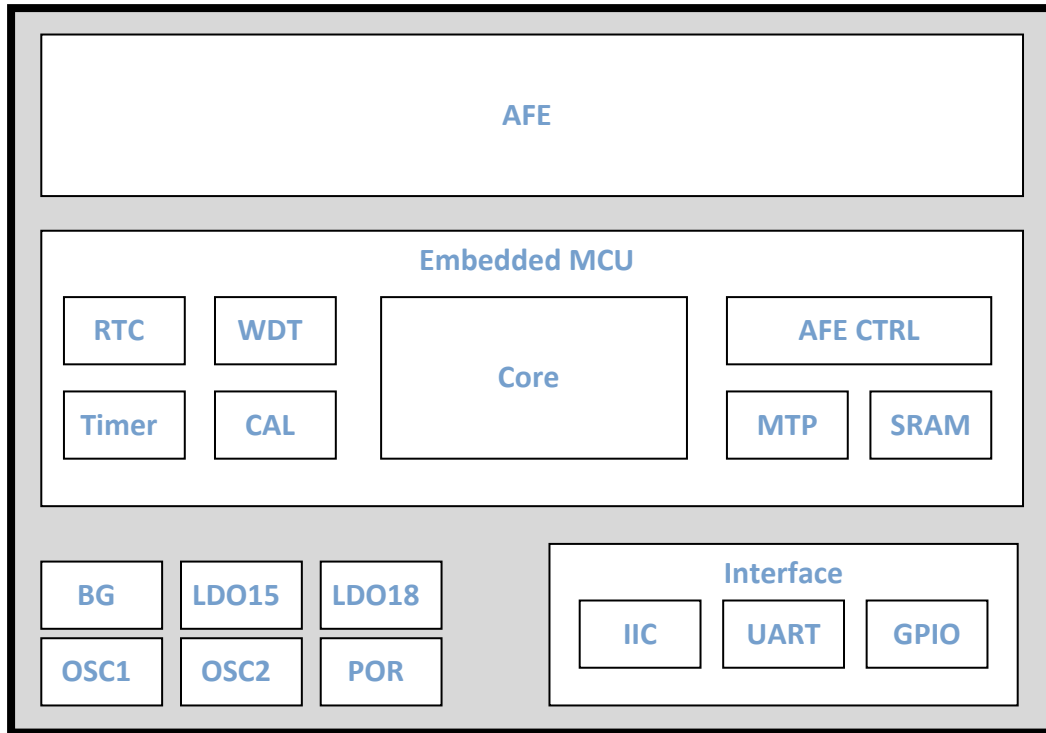

Figure: block diagram

2.1.1 AFE

AFE channels connect with CTP sensors, scan by sending AC signals to the sensors and process the received signals, which finally be converted by ADC and sent to MCU.

2.1.2 Interface

IIC is main communication interface which support slave mode only and support up to 400KHz transfer speed. Detail of IIC communication please refer to Chapter 3.

UART is normally used as debug function. It supports up to 1MHz baud rate.

GPIO (pins: "INT", "SDA", "SCL") high level voltage can be configurated to 1.8V or VDDA by setting internal register. "INT" signal is used to inform HOST to get touch information or just wakeup HOST.

2.1.3 Embedded MCU

Embedded MCU bases on a high efficiency core.

MTP is used to store firmware and run.

SRAM is for system use.

AFE CTRL module is the interface between MCU and AFE. User can configurate AFE CTRL registers to generate control signals to AFE. AFE also inform MCU current state through AFE CTRL module.

RTC works with OSC2. It is used to support low-power scan mode, in which OSC1 can be shut down and AFE scan is triggered automatically.

CAL module is designed for speeding up data process.

Timer can be used to generate a precise latency.

WDT is used to ensure the stability of chip when in operation.

Complex signal processing algorithms are implemented by MCU to detect the touch events reliably and efficiently. Communication protocol is also implemented by MCU to exchange touch or control information with HOST.

2.2 Work modes

There are four work modes available:

- Normal mode
- Idle mode
- LPWG mode
- Sleep mode

Work modes switching conditions are shown as below:

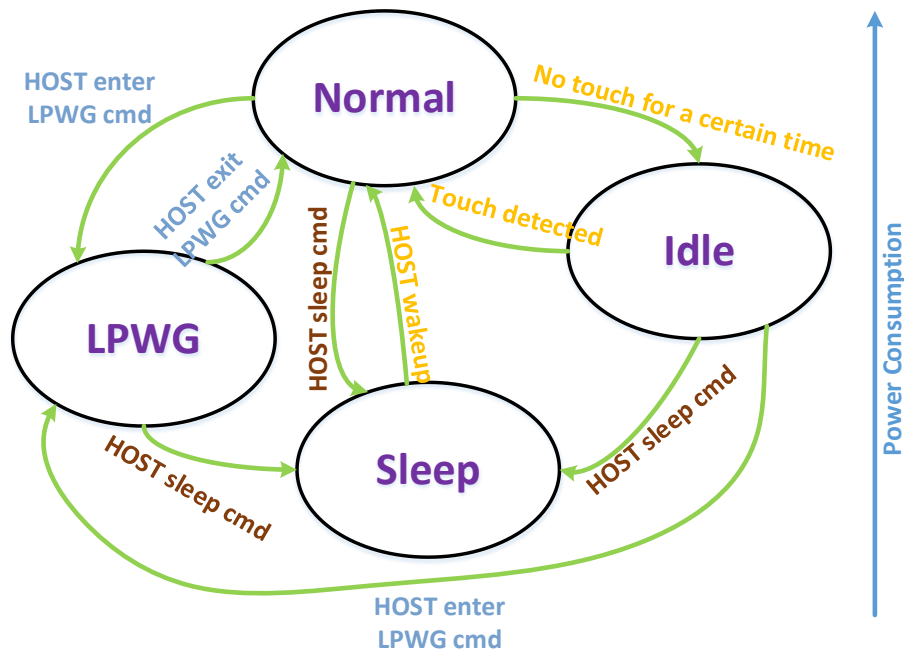

Figure: Work modes

2.2.1 Normal mode

In normal mode, AFE scans the touch screen panel, MCU will detect touch actions and report touch information in a configurable rate (Known as scan-rate or report-rate).

2.2.2 Idle mode

When there is no touch for a configurable interval, MCU automatically switch into idle mode. In idle mode, AFE scans the touch screen panel with a relatively lower scan-rate (also configurable) to reduce power consumption. Majority of the algorithms will be canceled, and only simple detection algorithms is retained to detect if there is a touch. Once a touch is detected, MCU will immediately switch back to normal mode.

2.2.3 LPWG mode

In LPWG (Low Power Wakeup Gesture) mode, AFE works more like idle mode but scans the touch screen panel in a more efficient way, so the power consumption can be reduced. In this mode, touch information would not be sent to HOST. Instead, MCU will inform HOST that the designed gesture is recognized. A simple way is, MCU pull down INT signal for a while, HOST can judge INT signal to wakeup system.

2.2.4 Sleep mode

In sleep mode, MCU enters ultra low-power mode and can be wakeup by IIC. The power consumption in this mode is extremely small, can greatly extend the standby time of portable devices.

3 Communication Interface

The connection from host to AXS5106S is shown as below:

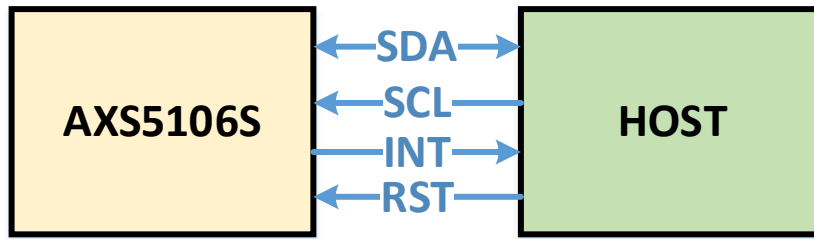

Figure: interface

INT signal is used to inform HOST that there are touch events and touch information is ready. INT signal idle level can be configured as low or high. When there are touch events, INT signal is set to active level until HOST read the touch information. If HOST haven't read the touch information, INT signal would retain active level until next touch events update. So, HOST can use either level or edge trigger-mode interrupt to respond INT signal.

RST signal is used to reset AXS5106S by setting low level for a while then setting back to high level.

IIC interface is used to transfer data between AXS5106S and HOST. Write/Read protocols are shown as below:



Figure: IIC write/Read operation



Figure: Host write AXS5106S register

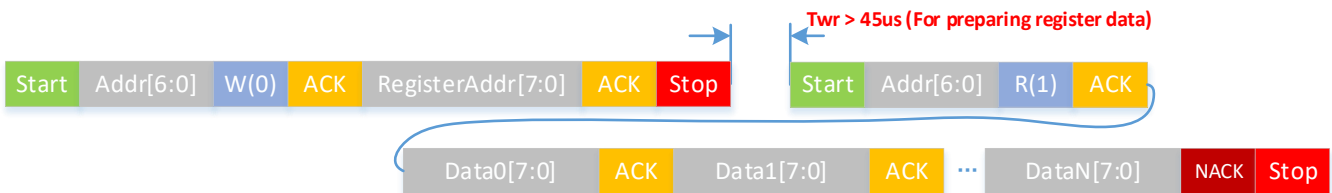

Host Read AXS5106S register

Figure: Host read AXS5106S register

4 Electrical Specifications

4.1 Absolute maximum ratings

Table: Absolute Maximum Ratings

Characteristics	Sym.	Min.	Max	Unit	Test Condition
Supply Voltage	VDDA	-0.3	5	V	
Storage temperature Range	T _{Str}	-55	150	°C	

4.2 Recommended operating condition

Table: Recommended operation condition

Item	Sym.	Min	Typ.	Max	Unit	Condition
Power-supply voltage	VDDA	2.7	3.3	3.6	V	
Operating Temperature Range	T _{Opr}	-40		85	°C	

4.3 AC characteristics

Table: AC Characteristics

Parameter	Sym.	Min	Typ.	Max	Unit	Condition
Digital inputs/outputs						
Input high voltage	V _{IH}	0.7 × IOVCC		IOVCC	V	
Input low voltage	V _{IL}	GND		0.3 × IOVCC	V	
Output high voltage	V _{OH}	0.7 × IOVCC		IOVCC	V	
Output low voltage	V _{OL}	GND		0.3 × IOVCC	V	

NOTE: IOVCC=VDDA or 1.8V

5 Package

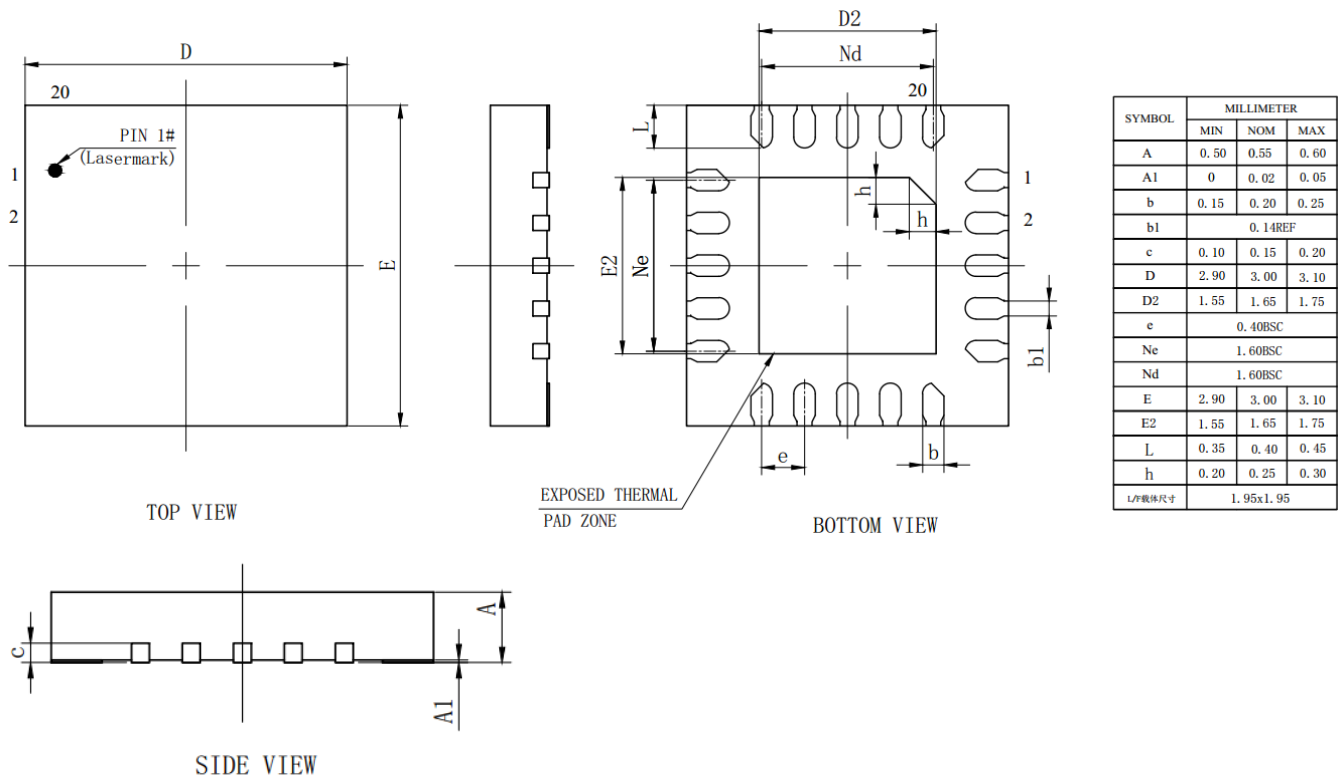

6 Ordering information

Product Series	Package Type	Packing Method	Ordering Number	Minimum Order Quantity
AXS5106S	20-pin 3x3x0.55mm QFN	TR	AXS5106S	5000

7 DISCLAIMER

The information appearing in this publication is believed to be accurate.

Integrated circuits sold by ChipSourceTek covered by the warranty and patent indemnification provisions stipulated in the terms of sale only. ChipSourceTek makes no warranty, express, statutory implied or by description regarding the information in this publication or regarding the freedom of the described chip(s) from patent infringement. Furthermore, ChipSourceTek makes no warranty of merchant ability or fitness for any purpose. ChipSourceTek reserves the right to halt production or alter the specifications and prices at any time without notice. Accordingly, the reader is cautioned to verify that the data sheets and other information in this publication are current before placing orders. Products described herein are intended for use in normal commercial applications. Applications involving unusual environmental or reliability requirements, e.g. military equipment or medical life support equipment, are specifically not recommended without additional processing by ChipSourceTek for such applications. Please note that application circuits illustrated in this document are for reference purposes only.